

D I M E N S I O N S

Height: 1.0 [25]

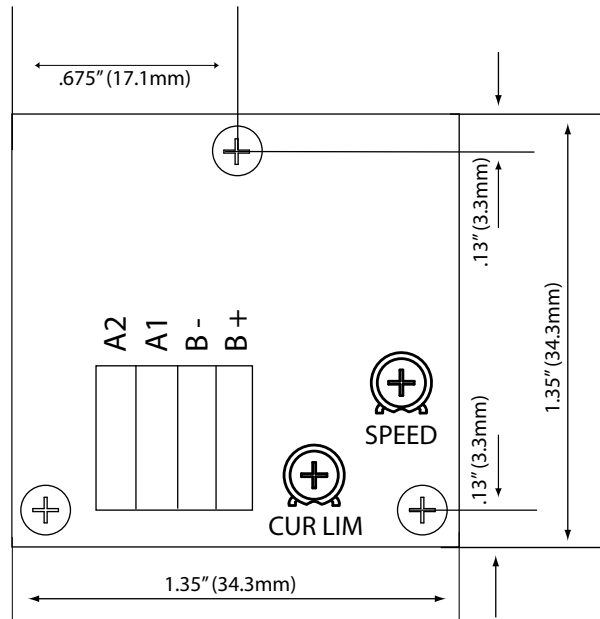

ALL DIMENSIONS IN INCHES [MILLIMETERS]

S P E C I F I C A T I O N S

	DC1.5-12	DC1.5-24
DC Input Voltage [V]	8 - 16	16 - 32
DC Output Voltage [V]	0 - 14.5*	0 - 29*
Continuous Current [A]	1	1
1 Minute Peak Current [A]	1.5	1.5
Current Limit Range [A]	0 - 1.5	0 - 1.5
Ambient Temperature [° C]	10 - 40	10 - 40

* Output Voltage range is equal to Input Voltage - 1VDC. The 1VDC drop is the result of having a reverse polarity protection diode. This diode can be removed for OEM's who do not need reverse polarity protection.



DC1.5-12
DC1.5-24

Low Voltage DC Drives

Q U I C K S T A R T G U I D E

C O N N E C T I O N S

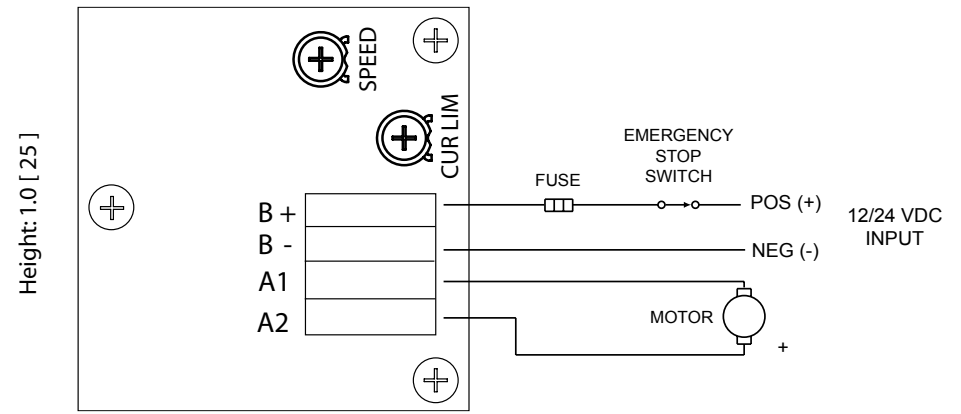

STEP 1: Wiring. Connect motor terminals to A1 and A2 (with A1 being positive). Connect DC input power to B+ and B-.

STEP 2: Basic Operation. Adjust SPEED trim pot clockwise (CW) to increase motor speed (voltage). Adjust SPEED trim pot counter clockwise (CCW) to decrease motor speed (voltage). The on board SPEED trim pot can be removed and replaced with a header for a remote speed pot connection for OEMs.

STEP 3: Current Limit Calibration. Remove DC input power to B+ and B-. Connect DC ammeter in series with the motor armature. Set SPEED trim pot to full CW. Set CUR LIM trim pot to full CCW. Lock motor shaft or apply a heavy load to the motor. Apply input power to B+ and B-. Slowly adjust CUR LIM trim pot clockwise until the armature current is 150% of motor rated armature current. Power down and remove stall or heavy load and DC ammeter from motor. This calibration is pre-calibrated by Minarik Drives for a 1.5 Amp output. Custom calibrations can be supplied to OEMs.